

# PitotShield V2™ Spec Sheet

## Body 77TBU, 77TBL 77TBS

- Length... 5.2 in (13.2 cm) 4.23 in (10.7 cm)
- Diameter. 2.25 in (5.7 cm) 2.25 in (5.7 cm)
- Weight.... 4.25 oz (120 g) 3.5 oz (99 g)

DAT p/n 77TB\*4701 (ORANGE RBF)

DAT p/n 77TB\*64 (NAS RED RBF)



### Body Materials - Body Contains NO METAL

- Polypropylene (BASF PP1200) Laser Sintered
- Only Hi-Temp Silicone Contacts Pitot Tube Surface
- PTFE Polymer Protects Tip of Pitot Tube
- Thermal Actuator: Silica, Water-soluble hydrocarbon, Reactive Temp: 135°F/57°C
- Operational Temp -40°F/-40°C to 130°F/54°C
- Activation Temp Tested -4°F/-20°C to 130°F/54°C

### RBF Streamer Options

- Red SAE/NAS-DAT P/N 461756-24**
  - 24 in (70 cm) x 3 in (7.6 cm)
  - Brass Grommet/Nylon cord/Al crimp
- Proprietary Hi-Visibility DAT P/N 4701HVS**
  - International Orange
  - Reflective Accent for Night Visibility
  - 18.5 in (47cm) x 2.25 in (5.7cm)
  - Brass Grommet/Nylon cord/Al crimp
- Custom Streamers Available**

### Total Assembled Weight w/Streamer:

**STD & Large:** 4.75oz (135g); **Short:** 4.0oz (113g)

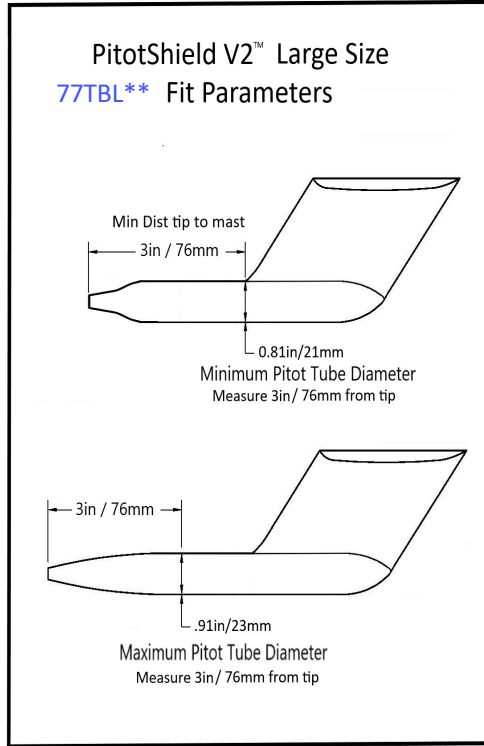
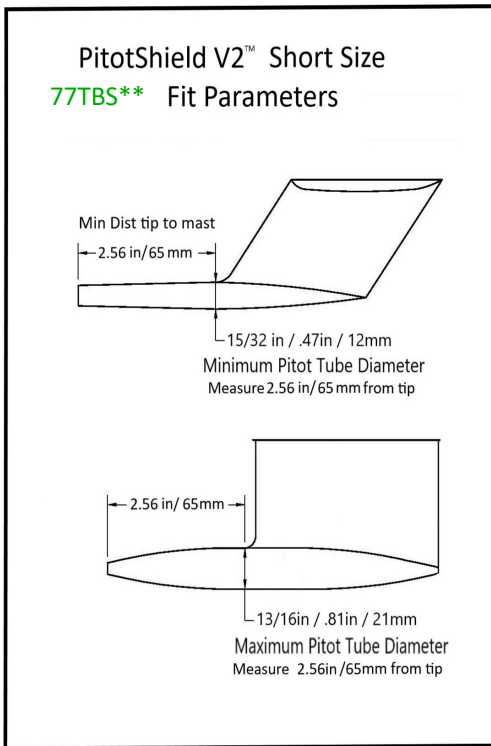
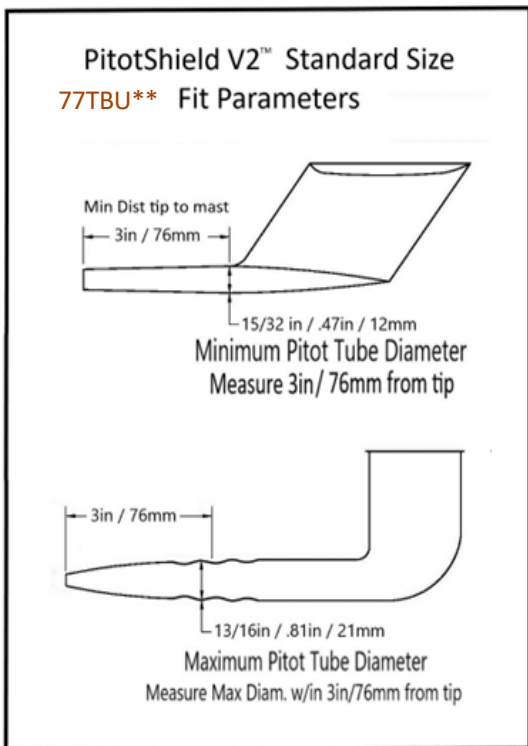
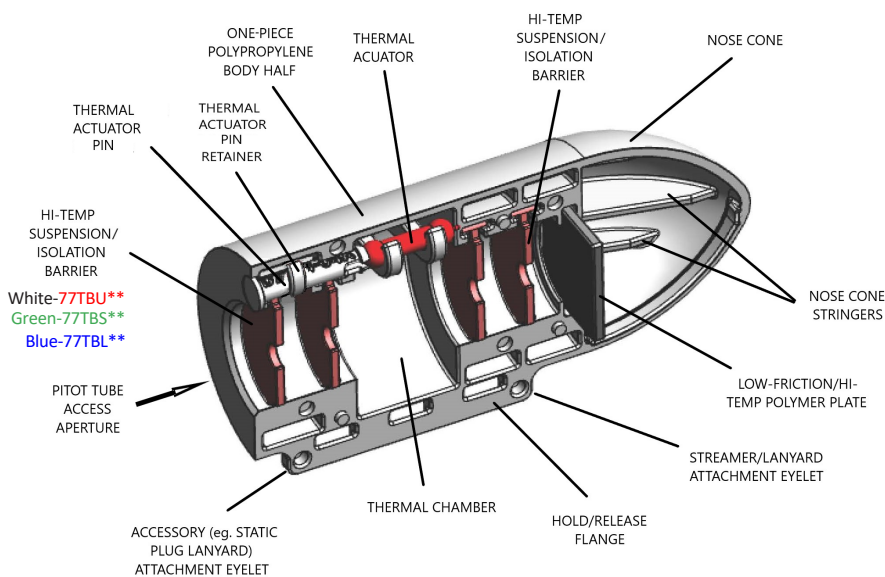

### APPLICATION/FITTING DETAILS

This **Standard-Size PitotShield V2™ Smartcover™** fits nearly all turbine aircraft round pitot tubes. If the tip of the pitot tube is less than 3in/76mm from the mast or the diameter at 3in/76mm from the tip is less than 0.47in/12mm, or the pitot tube diameter within three inches from the tip is greater than 13/16in (21mm), the **Standard PitotShield V2™ Smartcover™** will not fit.

### APPLICATION/FITTING DETAILS

This **PitotShield V2™-S (Short) SMARTCOVER™** fits round pitot tubes having a minimum length from the mast of 2.56in / 65mm and a maximum diameter of 0.81in/21mm.

### APPLICATION/FITTING DETAILS

This **PitotShield V2™-L (Large) Smartcover™** fits pitot tubes with a minimum length from the tip to mast of 3in/76mm and a maximum diameter from .81"/21mm to .91" within 3in (76mm) of the tip.